

自走式ロープウェイ
Zippar

zi Zip Infrastructure



Company Profile

Zip Infrastructure Co., Ltd.

Head Quarters

-Minamisoma City Fukushima Japan

Office

-Tokyo, Yokohama, Hadano

CEO of Company

-Takamasa Suchi

Found

-July 18th 2018

Team Members

-20



Problem

Traffic & Lack of Transportation

• Economic Loss cause from Traffic in Japan & ASEAN Top 5 countries reach to 550Billion ^{*1} US\$ per year

*1 Estimated from TomTom Research for time lost of traffic and minimum time wage of each country.

Demands

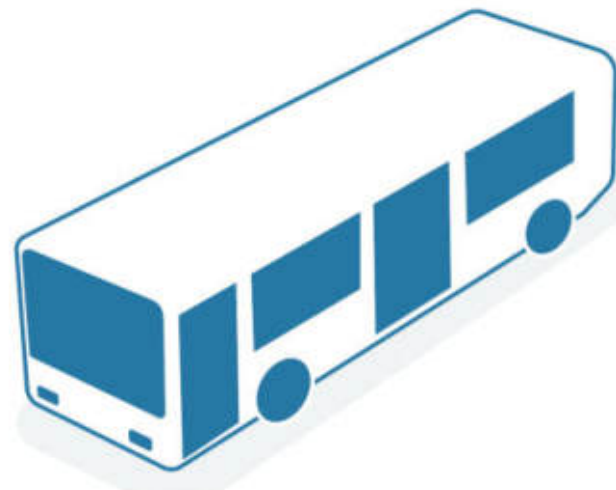
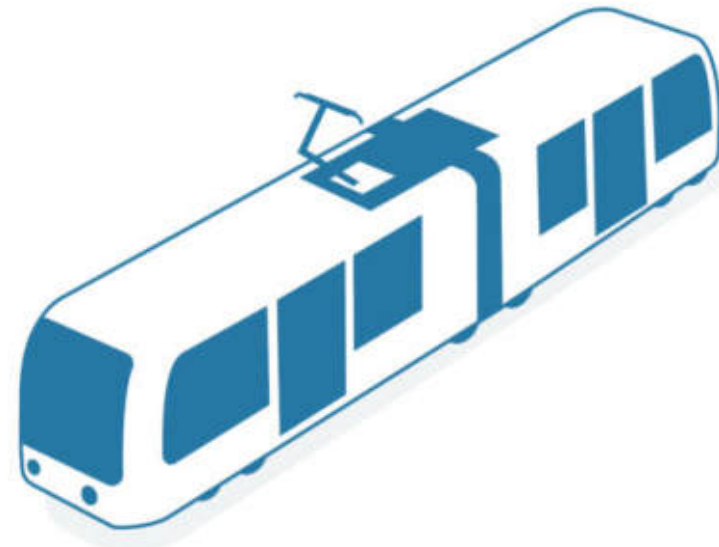
	Developers	Users
Buses 	<ul style="list-style-type: none">• Cheap• Easy construction• Lack of drivers	<ul style="list-style-type: none">• Arrival Delay• Stuck in traffic• Low frequency
Railways 	<ul style="list-style-type: none">• High cost• Decades for construction• Hard Land Acquisitions	<ul style="list-style-type: none">• Just in Time operation• Low affect from traffic• High frequency

Our Product



Zippar

A new type of Cable car enable curves and branches

Gondola



Station

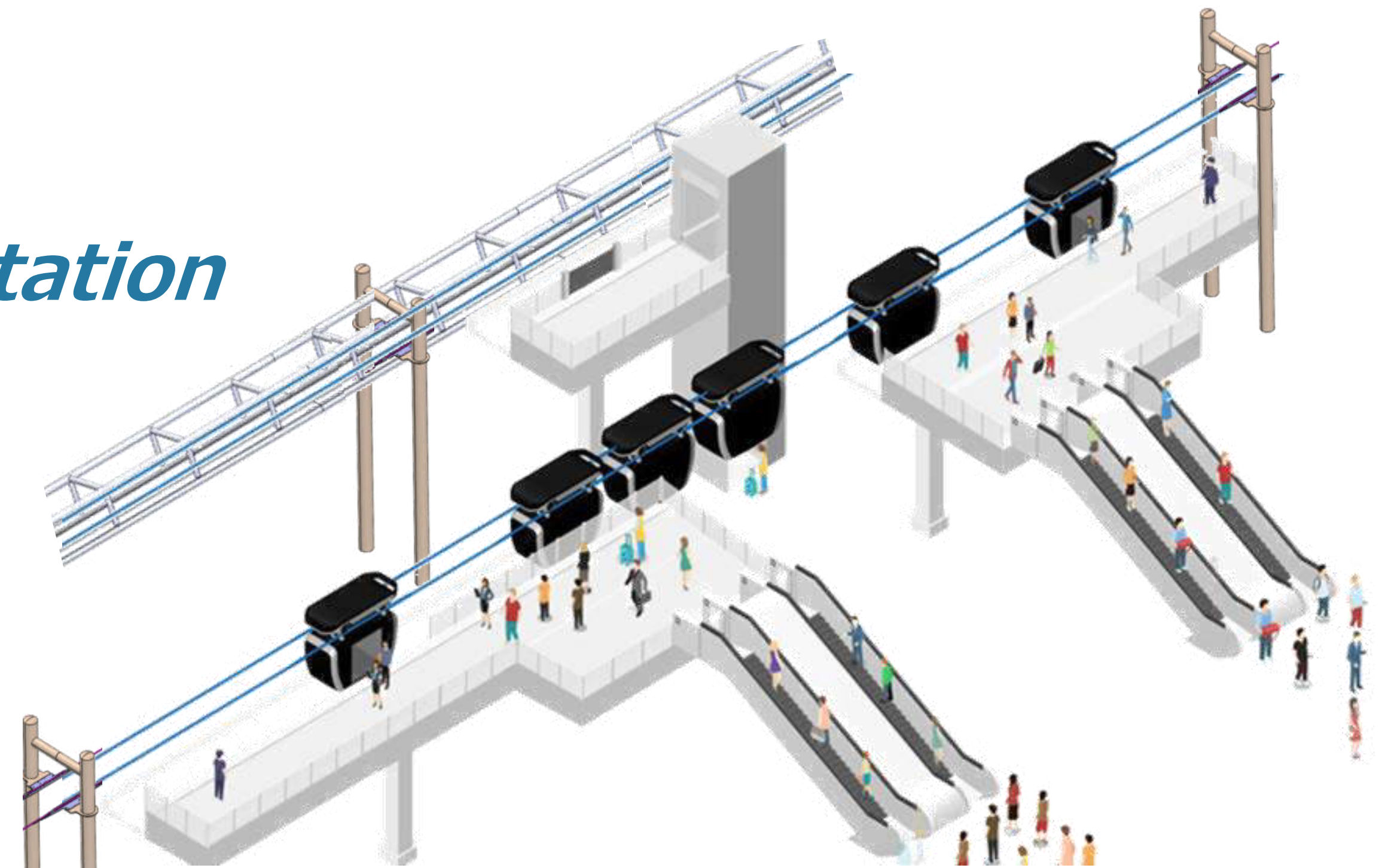

An isometric illustration of a city street scene. The street is light gray with white dashed lines for lane markings. Several small gray cars are driving along the road. On the right side of the street, there are several tall, rectangular buildings of varying heights. On the left side, there are shorter, blocky structures. Streetlights are positioned along the right side of the road. The overall style is clean and modern, using a limited color palette of grays and white.

Zippar

Difference

Normal cable cars

Cables are windup by machines in the station

Cables moving and the gondolas are fixed



Zippar

Self driven cable car, able to have curves

Cables are fixed and gondolas moves itself



Infrastructures

Columns are easy constructed on the road and has several types to fit

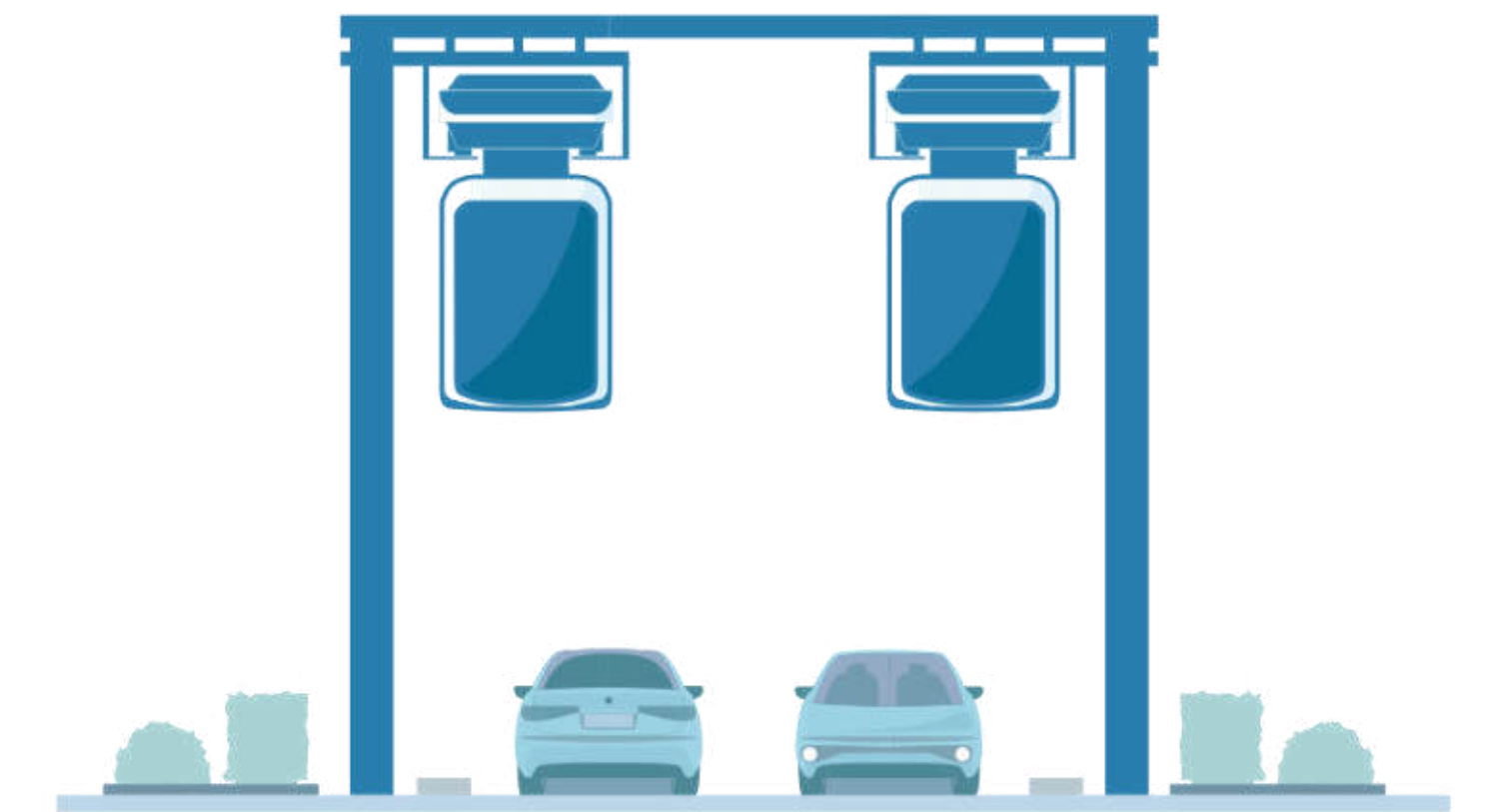
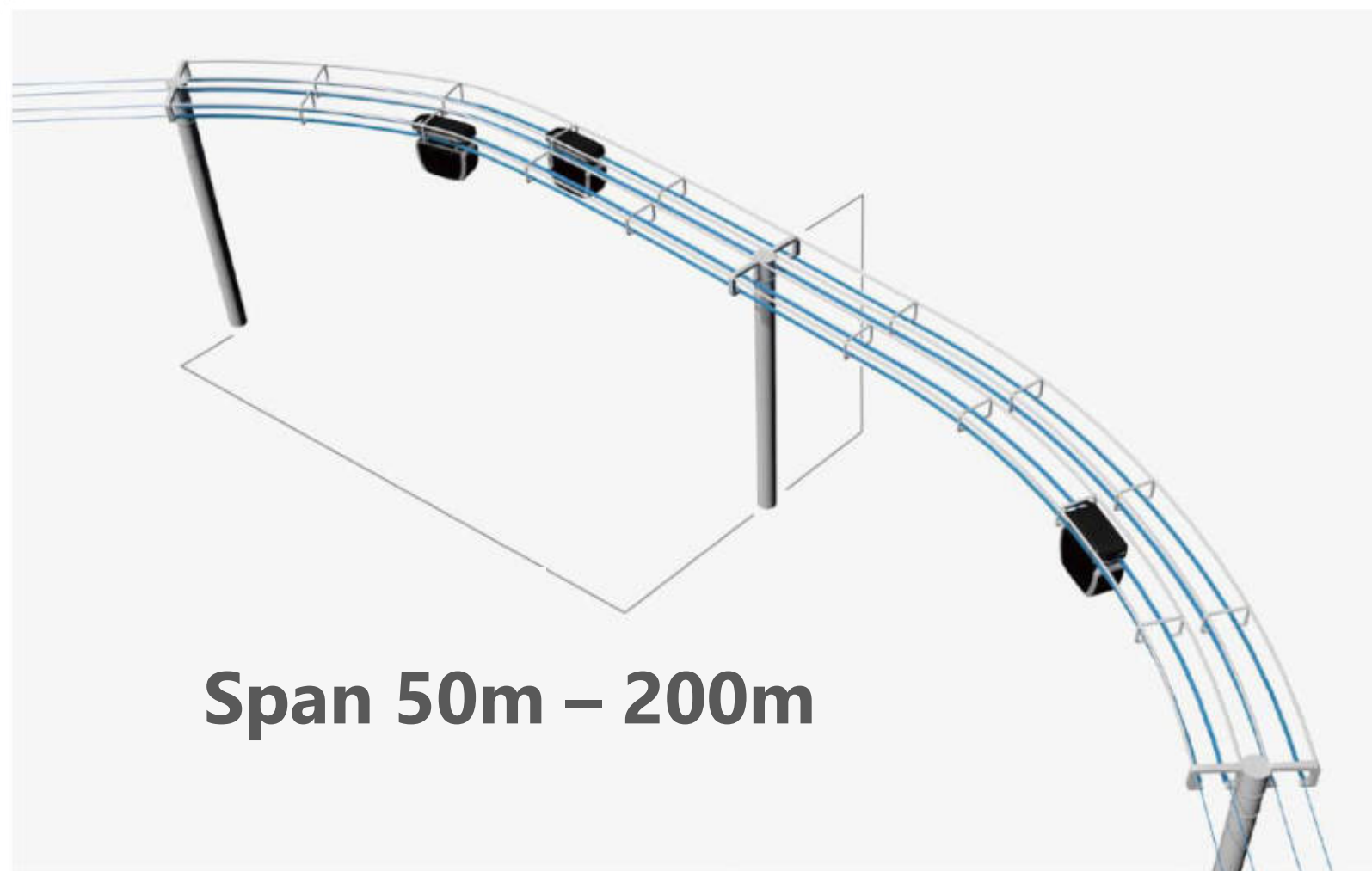

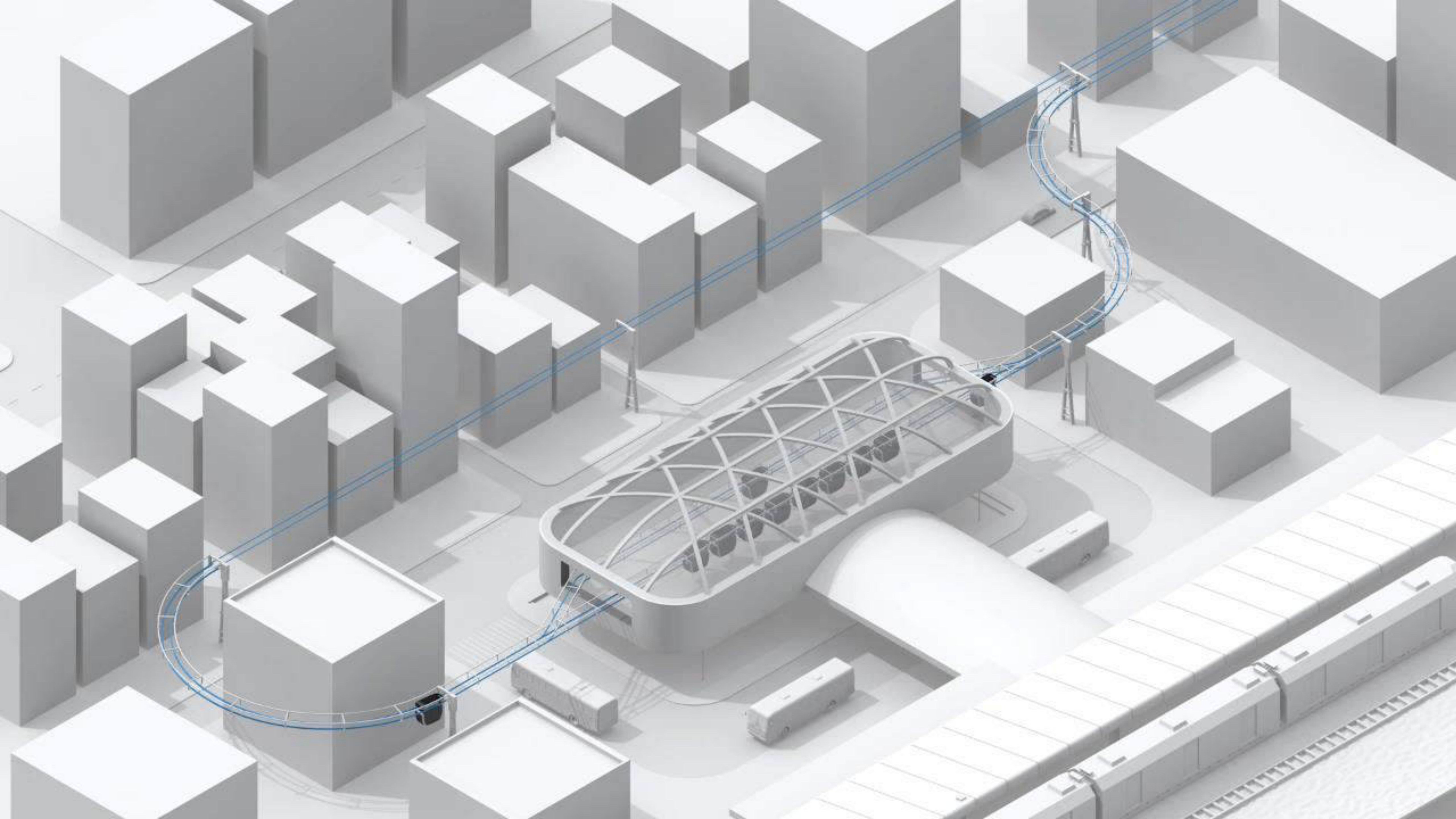

Advantages

Low cost



Zipcar

Railways

Use of cables leads low cost and short construction

Free design

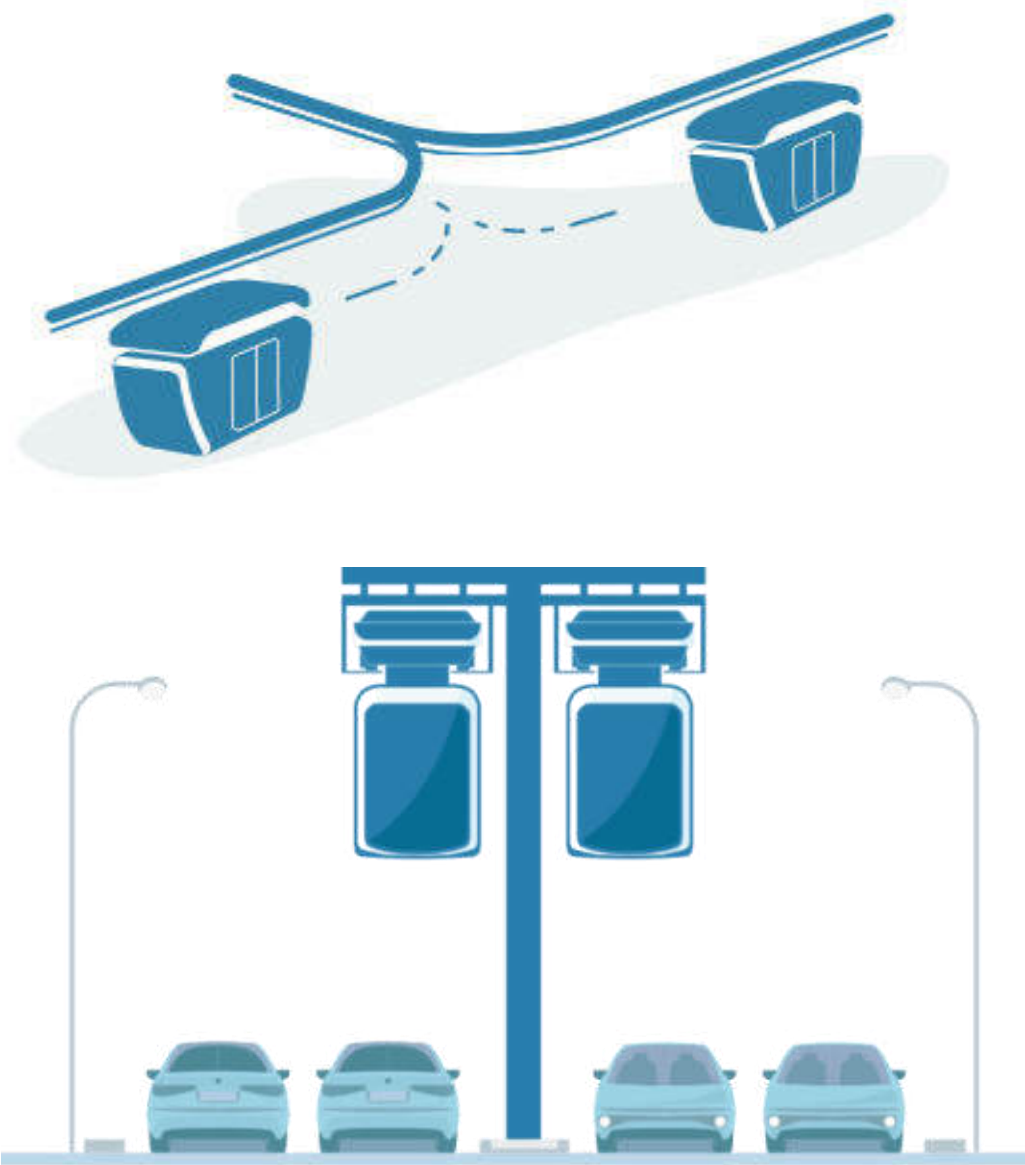

Curves and branches are easy and compact to introduce

Auto drive

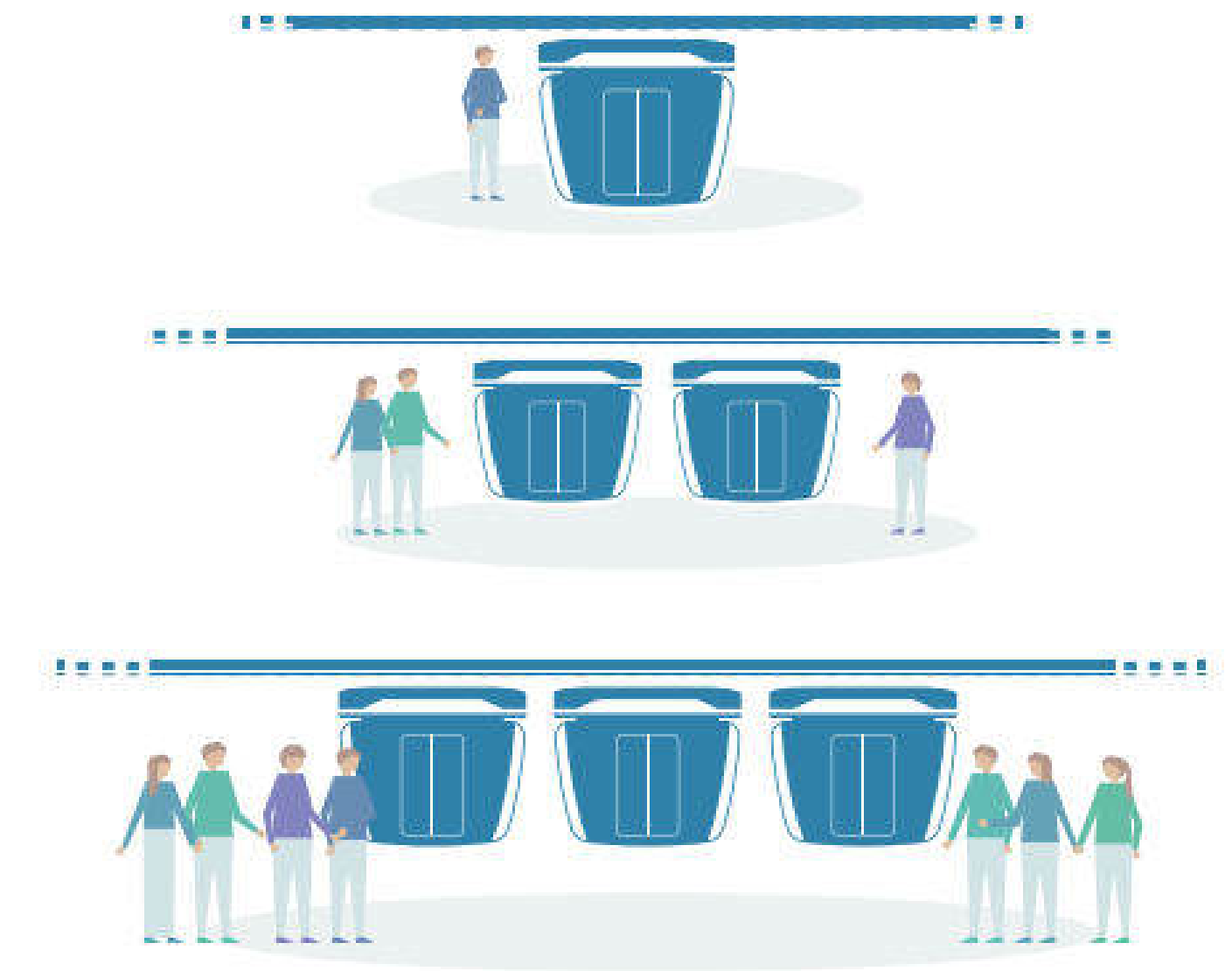

All cars are Unmanned driving and central controlled

Demands

	Developers	Users
 <p>Zippar</p>	<ul style="list-style-type: none">• 1/10 cost of railways• Min Land Acquisitions• Unmanned operation	<ul style="list-style-type: none">• Just in Time operation• Low affect from traffic• 12sec. operation

Target Area

Transport Capacity

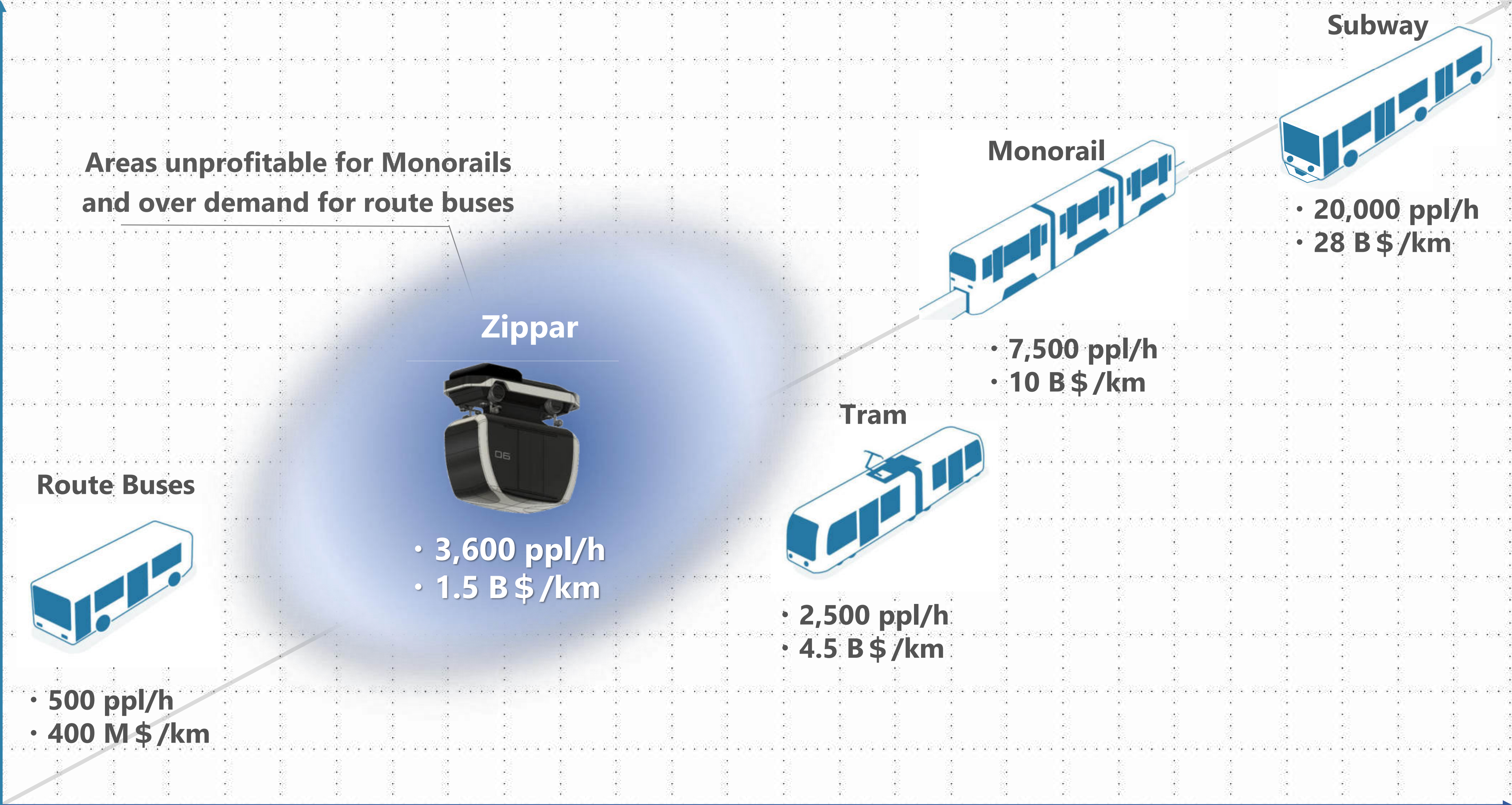

Areas unprofitable for Monorails and over demand for route buses

Zippar



• 3,600 ppl/h
• 1.5 B \$ /km

Route Buses

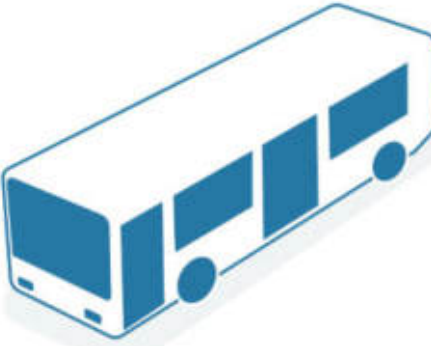

• 500 ppl/h
• 400 M \$ /km

Tram

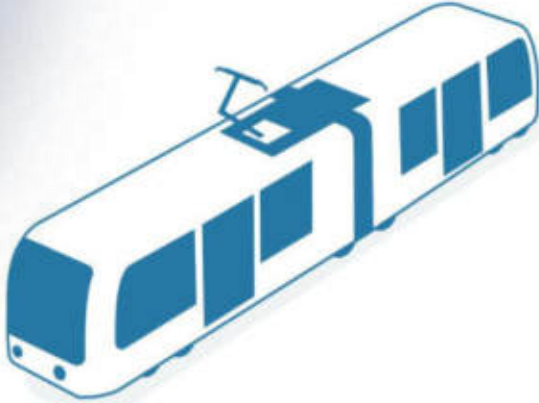

• 2,500 ppl/h
• 4.5 B \$ /km

Monorail

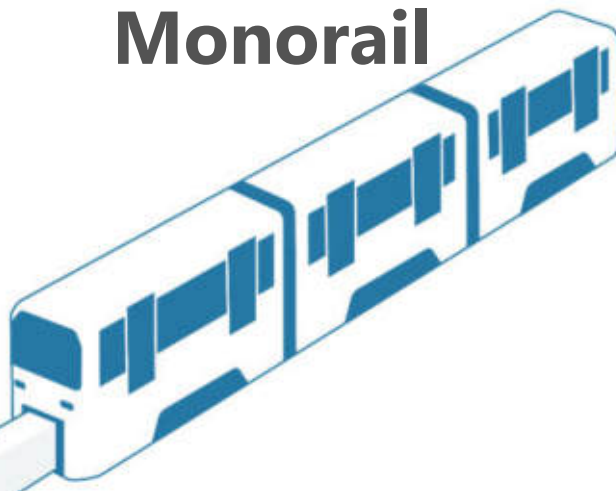

• 7,500 ppl/h
• 10 B \$ /km

Subway

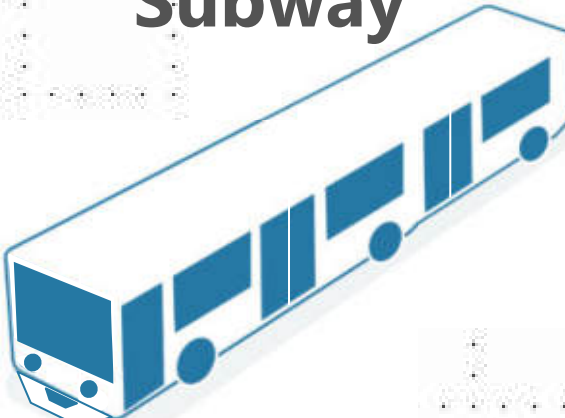

• 20,000 ppl/h
• 28 B \$ /km

Cost(Yen)



Bay areas

The land and sea are close, and high construction costs for the existing transportation system.



Large scale factories

To resolve commuting congestion due to factory relocation or new construction.

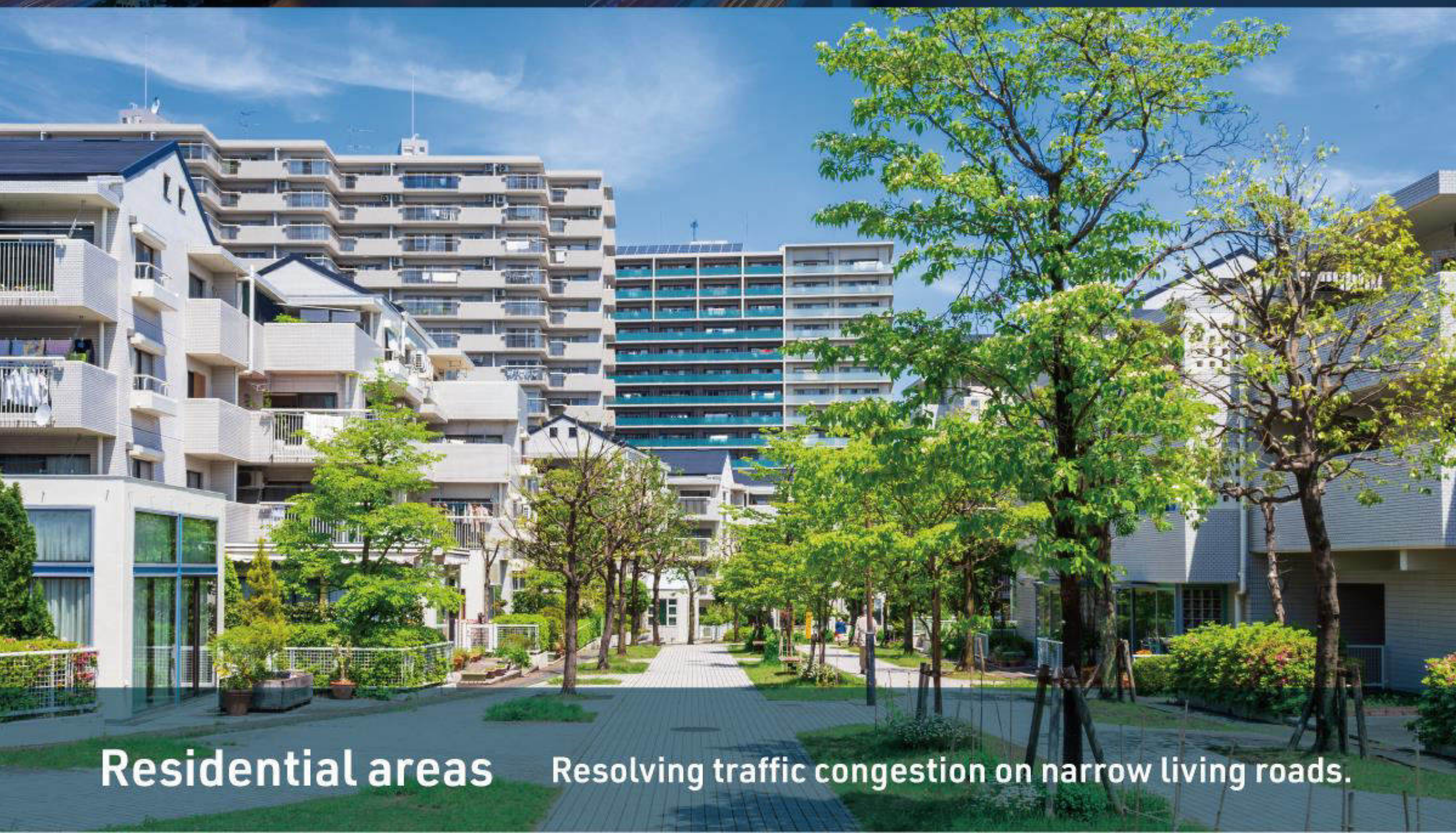

Residential areas

Resolving traffic congestion on narrow living roads.

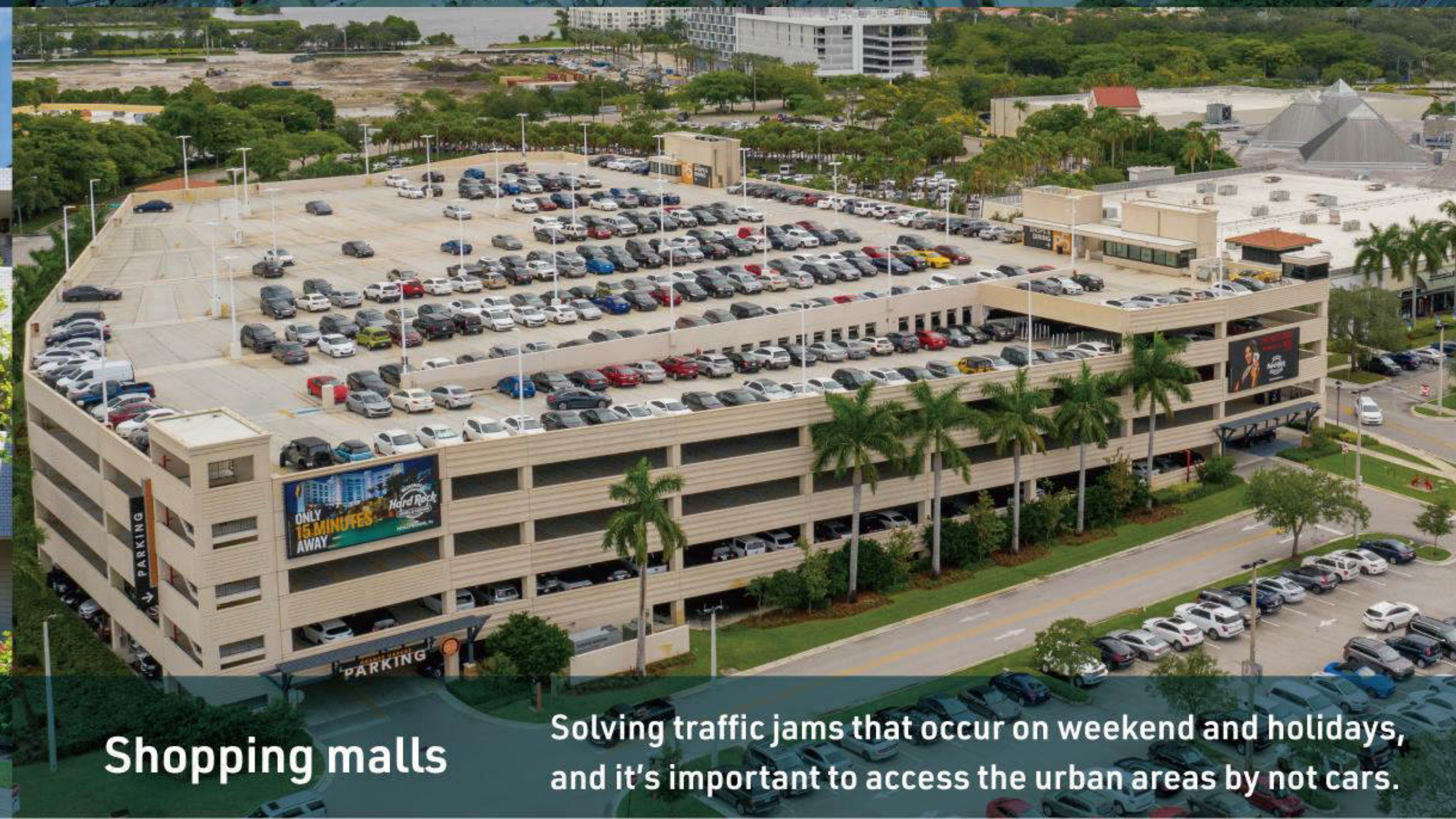

Shopping malls

Solving traffic jams that occur on weekend and holidays, and it's important to access the urban areas by not cars.

Development

2018

2020

2021

2023

2026

Phase 1

Phase 2

Phase 3

Phase 4



1/20 scale model

PoC

HADANO test line

FUKUSHIMA test line



Implementation

Kanagawa Prefecture



Fukushima Minamisoma City



Kanagawa Hadano City



Okinawa Tomigusuku City

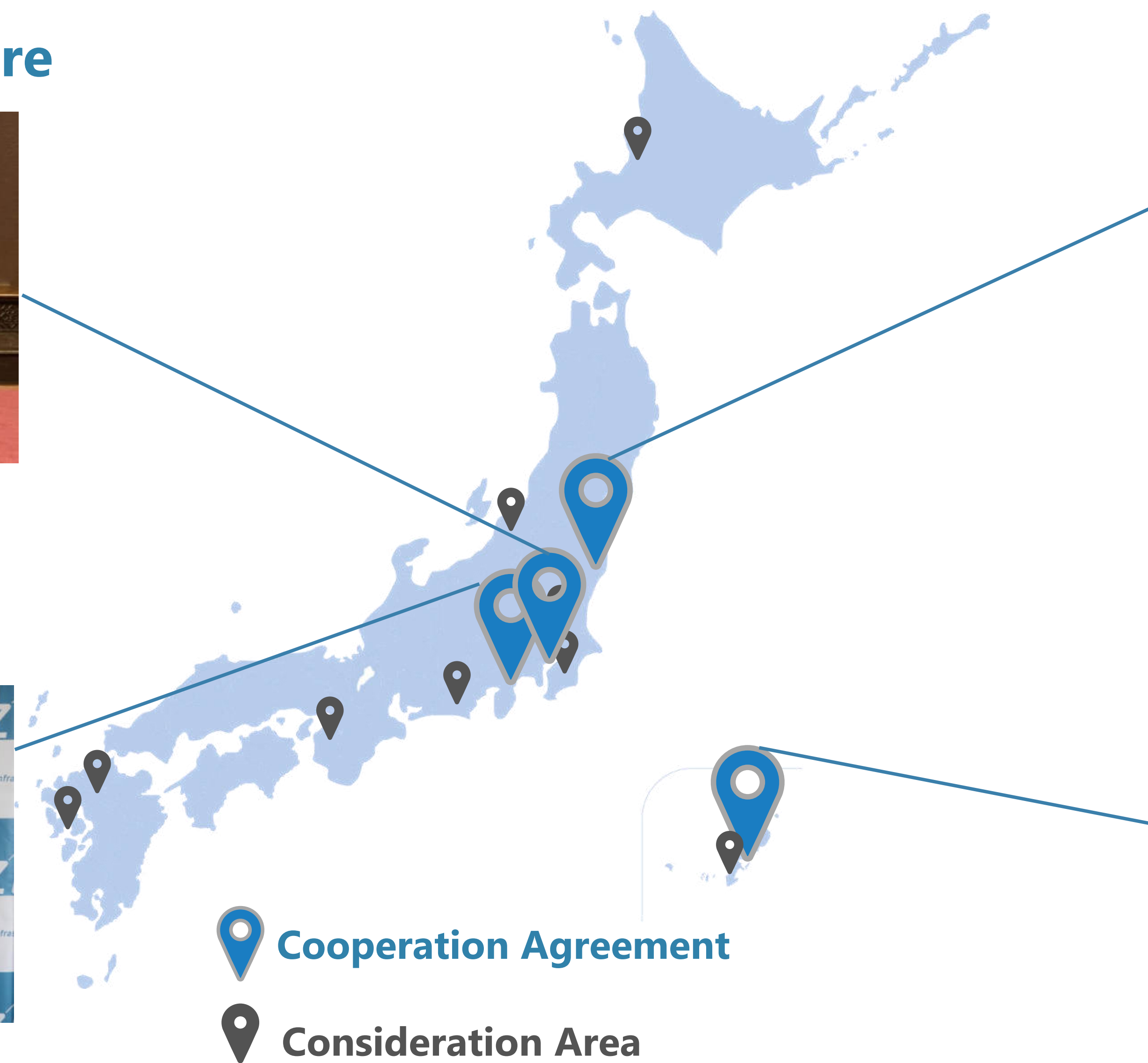

Roadmap

2023

2024

2025

2026

2027

2028

Phase 1

Authentication by
a third-party committee

Phase 2

Introduction of
the first domestic line

Phase 3

Expanding Zippar to
Southeast Asia

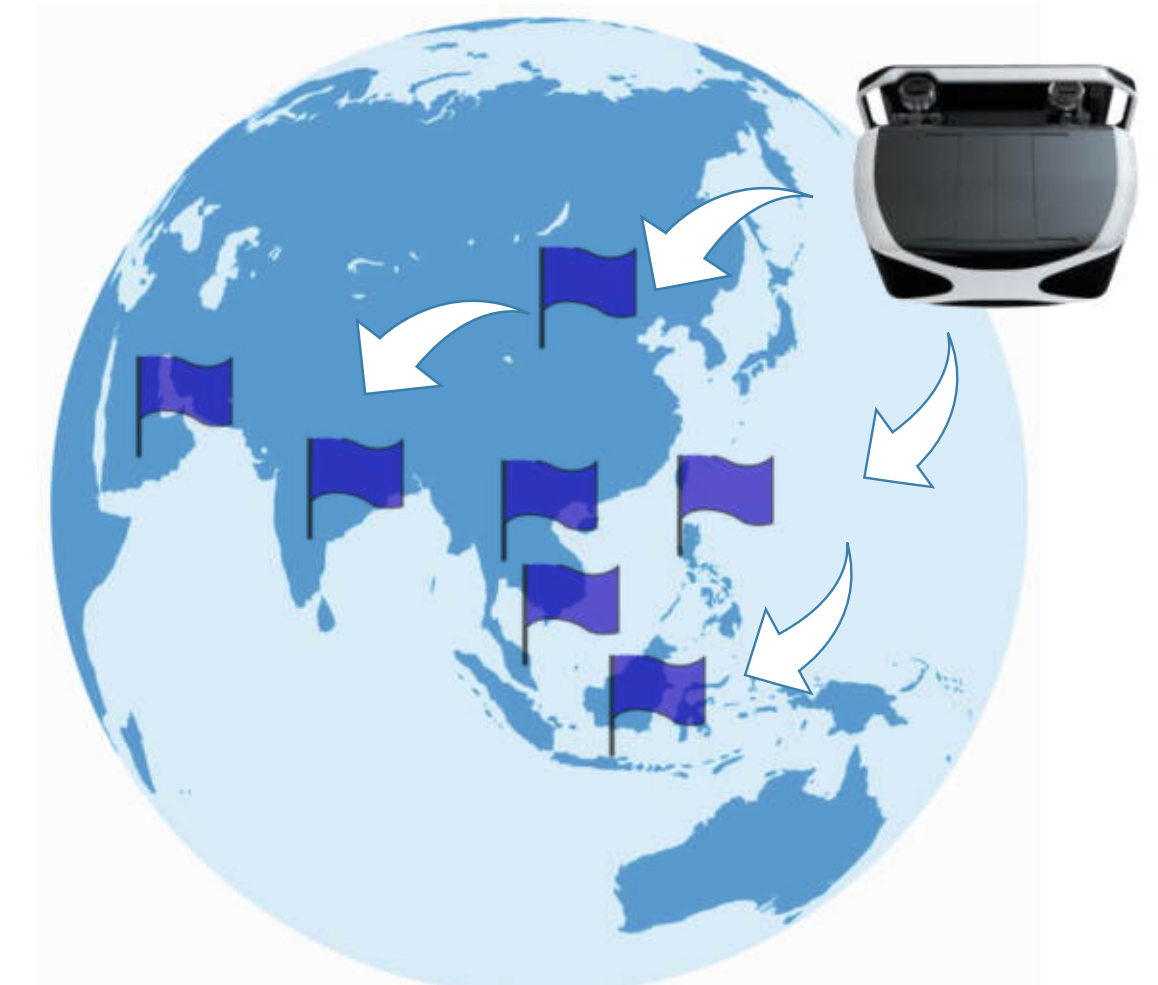



Our Goal

Revolution in Transportation

Revolution in Living area

Contact us for
more details



www.zip-infra.co.jp

